

NEW PRODUCT

Luxury Look... STAIR TREADS



MILL FINISH EACH	LENGTH	PRICE
	.9 mtr.	\$115
	1.0 mtr.	\$125
	1.2 mtr.	\$130
	1.8 mtr.	\$146
	2.4 mtr.	\$169

Manufactured from High Quality Extruded Aluminium in a Mill Finish.

Standard sizes available in: 900, 1000, 1200, 1800 and 2400mm.
Can also be cut to any length you require.

Has a Work Load Limit of 470 kg with a maximum span at 1200mm.

Dimensions: 250mm wide x 50mm high.

Supplied with 4 x 10mm hex bolts, nuts and washers to bolt to stringers.

Slotted groove for adjustable fixing position.
Non slip ribbed grooves on top and side surfaces for a safer grip area.

All treads completed with 2 cast alloy end caps. Each cap is secured by 2 large hidden rivets.

MULTI AWARD WINNING PRODUCT

PLANK CLAMP *Plank Magic*

AS SEEN ON TV

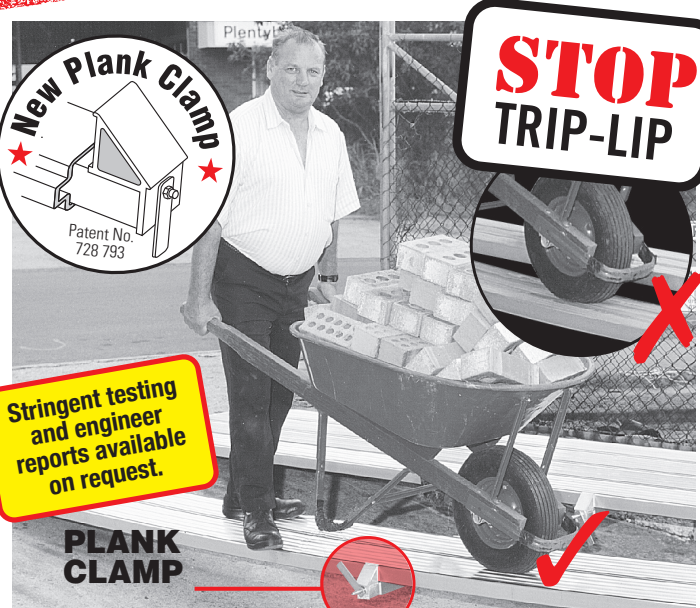

PLANK CLAMP JAW SIZES

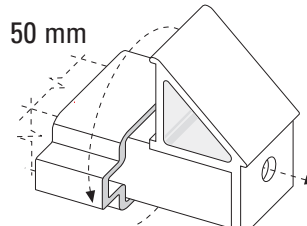

For ALUMINIUM PLANKS, clamp should be dismantled then reassembled with aluminium raised portion turned to the side.

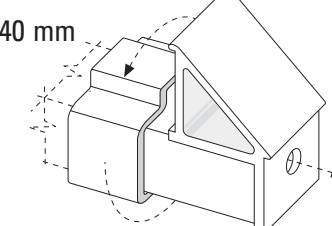

For HYPLANK LVL 40 mm PLANKS, clamp should be dismantled then reassembled with aluminium raised portion turned to the top.

SETTING A FIXED SIZE

In cases where the jaw size can remain fixed on a set size, the end of the threaded rod should be burred to prevent the locking handle becoming detached from the clamp.

The clamp can be used to clamp multiples of two, three or four planks to form a working platform. All platforms shall comply with the requirements of the latest edition of The Australian/New Zealand Standard, AS/NZS1576.1.

PLATFORM DUTY	LIGHT	MEDIUM
Min Platform Width	450mm	900mm
Min. Number Planks	Two (2)	Four (4)
Max. Point Load	100 kg	150 kg
Max. Total Load (per platform span) AS/NZS1576.1	225kg	450 kg

When clamped together with a single clamp at midspan, the scaffold planks forming either Light or Medium Duty platforms, or ones with three planks wide, may be supported at the following maximum span positions.

STANDARD PLANK LENGTH & TYPE	MAXIMUM PLATFORM SPANS & OVERHANG FOR LIGHT OR MEDIUM DUTY PLATFORMS
6.0 m Aluminium Planks	— 5500 mm Span and 250 mm Overhang
Hyplank LVL Planks (40 mm thick)	— 3400 mm Span and 250 mm Overhang

NOTE:-
a) These spans are based on two supports only per platform plank length.
b) Should longer standard plank lengths be used, three supports evenly spaced will be necessary, with lesser spans than those specified herewith.
c) These spans are suitable for three plank width platforms with maximum point and total loads of 125 kg and 325 kg, respectively.

- 2 Plank Model - \$75 each
- 3 Plank Model - \$80 each
- 4 Plank Model - \$85 each

...feels like a dance floor.

A GREAT NEW CONCEPT IN PLANK SAFETY.
Our new plank clamp solves the problems associated with trip-lip conditions, while working on two or more planks.

Plank Magic not only proves to be safe, but it can also halve the sag, double the strength of the planks and also improves the slide grip of planks to between 29% and 80%.

- Robust aluminium construction
- 2 Plank model weighs 2.4 kg
- Feel and work safer • Work faster



PRICES INCLUDE GST

FULL

TOMMY TUCKER SAFETY SYSTEM

This system won the Workplace Health & Safety Small Business of the Year Award 1999
Patent No. 736 211

UP-GRADE YOUR TRESTLES TO LIGHT DUTY SCAFFOLD 225KG WORKING LOAD LIMIT

To up-grade your Trestles to the 225kg working load limit, this Safety System fits all Tommy Tucker Aluminium Trestles from 1987 onwards of this extrusion shape

HAND RAIL SWIVEL \$55.00 EACH

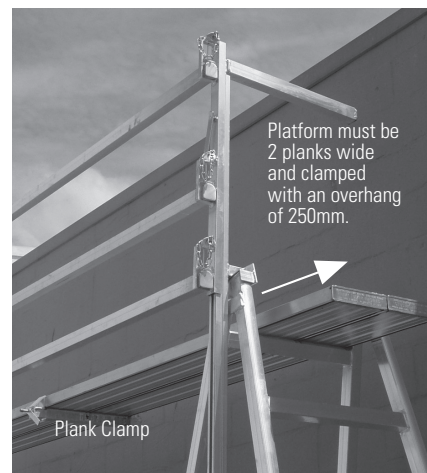

Plank Clamp

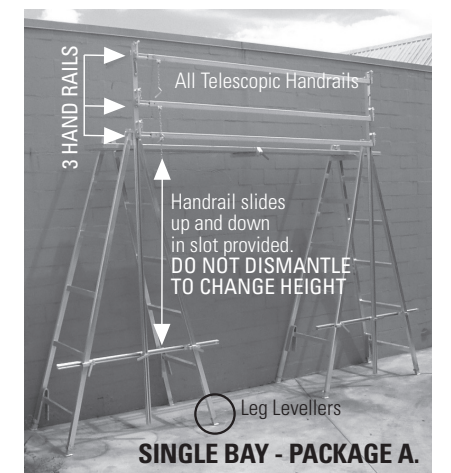

3 HAND RAILS All Telescopic Handrails Handrail slides up and down in slot provided. DO NOT DISMANTLE TO CHANGE HEIGHT Leg Levelers SINGLE BAY - PACKAGE A.



3 HAND RAILS All Telescopic Handrails Handrail slides up and down in slot provided. DO NOT DISMANTLE TO CHANGE HEIGHT Leg Levelers 2 BAY - PACKAGE B.

WINNER OF 9 AWARDS IN 4 YEARS



- Hire & Rental Association Award - 1997
- Health & Safety Award - 1997
- Hire & Rental Association Award - 1998
- Master Builders Award - 1998
- Health & Safety Small Business of the Year Award - 1999
- 1st Prize - H.I.A. Safety System - 2000
- H.I.A. Award - Saw Bench - 2000
- H.I.A. Award - Plank Clamp - 2000
- H.I.A. Award Saw Bench 2001

PROVEN SAFETY ASPECTS OF OUR UNIQUE SYSTEM AFTER 16 YEARS OF FEEDBACK

Out-Riggers are unavailable for the following reasons. Wherever there is sufficient space to stand up the trestle the counterweights can be used. Our experience with thousands of customers who use the trestle systems, suggest that they prefer to use the counterweights. However, those who have used the outriggers complain that there are many circumstances where they just don't work, with the result that workers are unnecessarily exposed to higher risk.

- Where there is a lack of space such as in the housing industry, particularly with small lot housing.
- Where the ground is too soft to properly support the outrigger, this common cosmetic approach to stability is a potential trap.
- Where there is a steep embankment, sloping either toward or away from the Trestle System is another common scenario.

In practice outriggers are often not installed correctly giving the operators a false sense of security and is not practical in circumstances such as the following:
Alternatively, counterweights that are cheap to purchase, unattractive to the thief while very quick and easy to install, make a more positive contribution to the practicability and stability of the system. We agree with our engineer's opinion that "a stability system that is more likely to be used is an inherently safer system".

It is also worth noting that this system has been in widespread use now for a number of years and soon after it was launched, won us the Business of the Year 1999 Queensland Health & Safety award. The system has continued to win other awards for our company, of which we here at Tommy Tucker Trestles are very proud.



"PACKAGES DO NOT INCLUDE TRESTLES, PLANKS & CLAMPS"

PACKAGE A. SINGLE BAY SYSTEM

2 x MASTER POSTS (Fits all models)	\$240.00
2 x SPREADER BARS	\$215.00
3 x TELESCOPIC HANDRAILS (3.3m to 6.250m)	\$345.00
2 x STOP ENDS	\$ 80.00
4 x COUNTERWEIGHTS (Galvanised)	\$220.00
TOTAL PRICE	\$1,100.00

Please add one PLANK CLAMP - if you don't yet own one.
\$75.00 Each

The REGULATIONS stipulate that the full system above must be used and not part there-of.

PACKAGE B. 2 BAY SYSTEM

3 x MASTER POSTS (Fits all models)	\$360.00
3 x SPREADER BARS	\$322.50
6 x TELESCOPIC HANDRAILS (3.3m to 6.250m)	\$690.00
2 x STOP ENDS	\$ 80.00
6 x COUNTERWEIGHTS (Galvanised)	\$330.00
TOTAL PRICE	\$1,782.50

Please add two PLANK CLAMPS - if you don't yet own any.
\$75.00 Each

PRICES INCLUDE GST

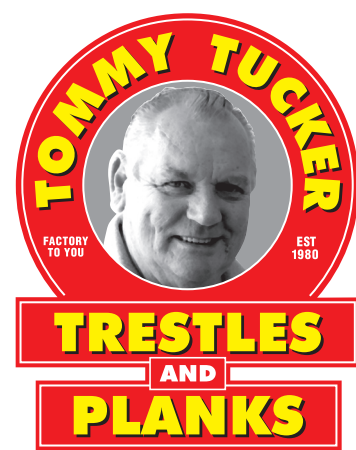

MAR 2023

For help plus cooperation
Call: **07) 3290 2705**

8-10 Kenway Drive
Underwood Q 4119 (off Kingston Road)
sales@tommytuckertrestles.com.au

www.tommytuckertrestles.com.au
Tommy Tucker Trestles Pty Ltd - ABN 73 010 925 783

ESTABLISHED 1980

TRADE PRICE LIST

All prices include 10% GST. / Prices subject to change without notice. / Prices correct at time of printing March 2023.

Nine Awards in Four Years

Workplace Health & Safety Innovation Award 1999 Small Business Category

Multi-Award Winning Products

- Hire & Rental Association Award - 1997
- Health & Safety Award - 1997
- Hire & Rental Association Award - 1998
- Master Builders Award - 1998
- 1st Prize - H.I.A. Safety System - 2000
- H.I.A. Award - Saw Bench - 2000
- H.I.A. Award - Plank Clamp - 2000
- H.I.A. Award Saw Bench - 2001

Opening Hours: 7am to 5pm - Monday to Friday
9am to 12 midday Saturday

Manufacturers of Industrial:

- Platform Trestles
- Aluminium Stools
- Aluminium Trestles
- Aluminium Step Treads
- Aluminium Planks
- Drop Saw Benches
- Plasterers Trestles
- Plank Clamps
- Bricklayers Trestles
- Trestle Safety Systems

PROUDLY Australian Owned & Made

STANDARD PAINTERS TRESTLES ADJUSTABLE



DELIVERY TO ALL BRISBANE SUBURBS

PRICE EACH	HEIGHT	PRICE EACH
\$220	.9 mtr. (3 ft.)	\$320
\$245	1.2 mtr. (4 ft.)	\$345
\$270	1.5 mtr. (5 ft.)	\$370
\$295	1.8 mtr. (6 ft.)	\$395
\$320	2.1 mtr. (7 ft.)	\$420
\$345	2.4 mtr. (8 ft.)	\$445
\$380	2.7 mtr. (9 ft.)	\$480
\$410	3.0 mtr. (10ft.)	\$510
\$435	3.3 mtr. (11ft.)	\$535
\$460	3.6 mtr. (12ft.)	\$560
\$480	3.9 mtr. (13ft.)	\$580
\$500	4.2 mtr. (14ft.)	\$600
\$520	4.5 mtr. (15ft.)	\$620
\$540	4.8 mtr. (16ft.)	\$640

1000 IN STOCK

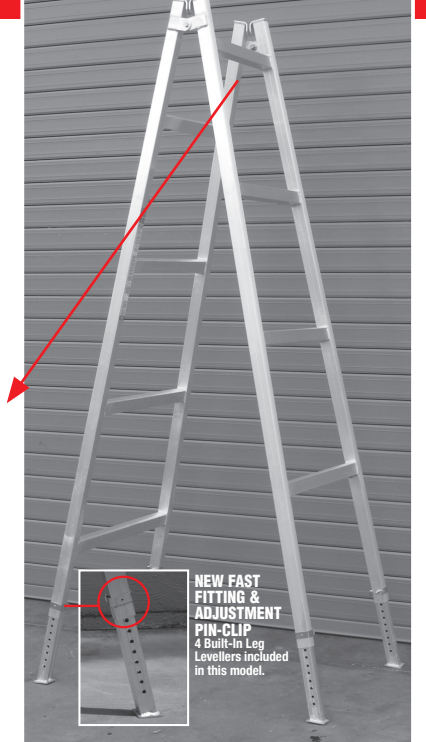

NEW FAST FITTING & ADJUSTMENT PIN-CLIP
4 Built-in Leg Levelers included in this model.

ALUMINIUM PLANKS

WITH WELDED END CAPS PLUS 4 RUBBER INSERTS

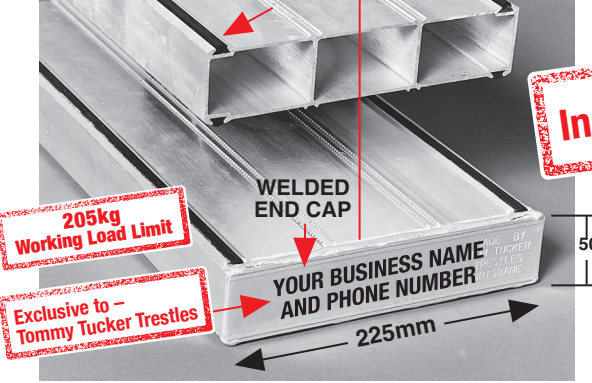

205kg Working Load Limit
Exclusive to - Tommy Tucker Trestles

Industrial Quality

Plank caps can be stamped with your name and phone number.
AT NO CHARGE
(Maximum 2 lines of 18 characters each - including blank spaces)

LENGTH	PRICE EACH	LENGTH	PRICE EACH
1.0 mtr.	\$85	3.6 mtr.	\$196
1.2 mtr.	\$93	4.0 mtr.	\$212
1.5 mtr.	\$104	4.2 mtr.	\$220
1.8 mtr.	\$116	4.8 mtr.	\$243
2.0 mtr.	\$124	5.0 mtr.	\$251
2.4 mtr.	\$139	6.0 mtr.	\$290
2.7 mtr.	\$151	7.0 mtr.	\$329
3.0 mtr.	\$163	8.0 mtr.	\$368

PRICES INCLUDE GST

NEW PRODUCT

Adjustable ALUMINIUM BRICKLAYERS TRESTLE

Light, Compact, Folds Flat, Strong.

(330kg Working Load Limit)

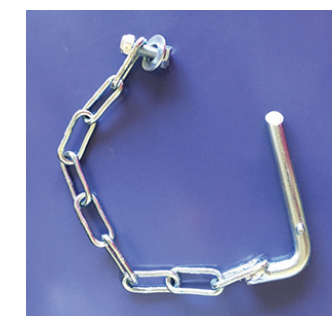

LARGE ADJUSTABLE \$305
1150 to 1900mm High

SMALL ADJUSTABLE \$245
820 to 1250mm High

REPLACEMENT PIN, CHAIN, NUT, BOLT and WASHER \$11.00 each



2000kg Bay Load Test



Trestle Post - \$55 each
Telescopic Handrails (3.3m to 6.250m) - \$115 each
Stop Ends - \$40 each

Safety Hand Rail System can be fitted to one side or both sides of the platform.



PLANK CLAMP 4 Plank Model \$85 each

AS SEEN ON TV

ONLY 15kg

ONLY 11kg

PRICES INCLUDE GST

PLASTERERS STOOLS

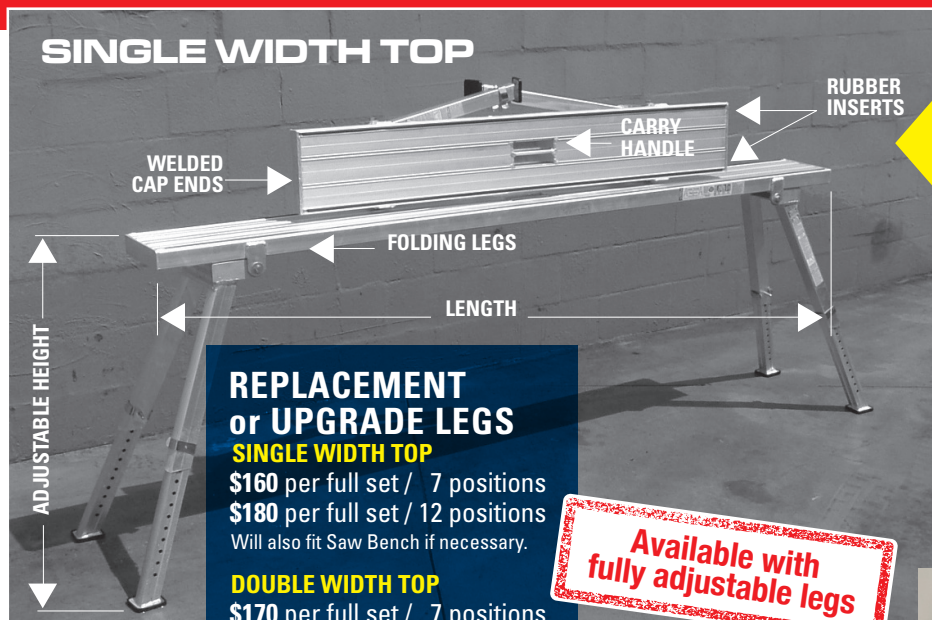

REPLACEMENT or UPGRADE LEGS

SINGLE WIDTH TOP
\$160 per full set / 7 positions
\$180 per full set / 12 positions
Will also fit Saw Bench if necessary.

DOUBLE WIDTH TOP
\$170 per full set / 7 positions
\$190 per full set / 12 positions

Available with fully adjustable legs

SINGLE WIDTH TOP

7 POSITION LEG HEIGHT FROM 470 to 620mm	STOOL LENGTH	12 POSITION LEG HEIGHT FROM 570 to 870mm
\$267	1.0 metres	\$288
\$275	1.2 metres	\$295
\$289	1.5 metres	\$309
\$299	1.8 metres	\$319
\$307	2.0 metres	\$327
\$322	2.4 metres	\$342
\$334	2.7 metres	\$354
\$346	3.0 metres	\$366
\$367	3.6 metres	\$389



Pin clip \$8.50 each



SAFER WORK PLATFORM DOUBLE WIDTH STOOLS
(2 plank wide)

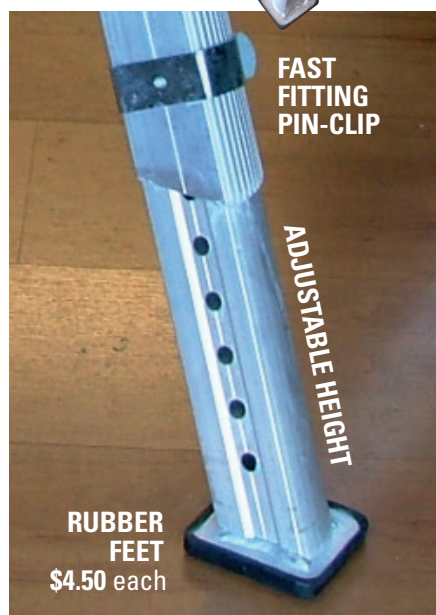

DOUBLE WIDTH TOP

7 POSITION LEG HEIGHT FROM 470 to 620mm	STOOL LENGTH	12 POSITION LEG HEIGHT FROM 570 to 870mm
\$360	1.0 metres	\$380
\$383	1.2 metres	\$396
\$399	1.5 metres	\$419
\$422	1.8 metres	\$442
\$445	2.0 metres	\$469
\$472	2.4 metres	\$489
\$493	2.7 metres	\$513
\$519	3.0 metres	\$536
\$563	3.6 metres	\$583

PRICES INCLUDE GST

DROP SAW WORK BENCH

COMPACT

• SIMPLE • POSITIVE • COMPACT • EASY TO STORE

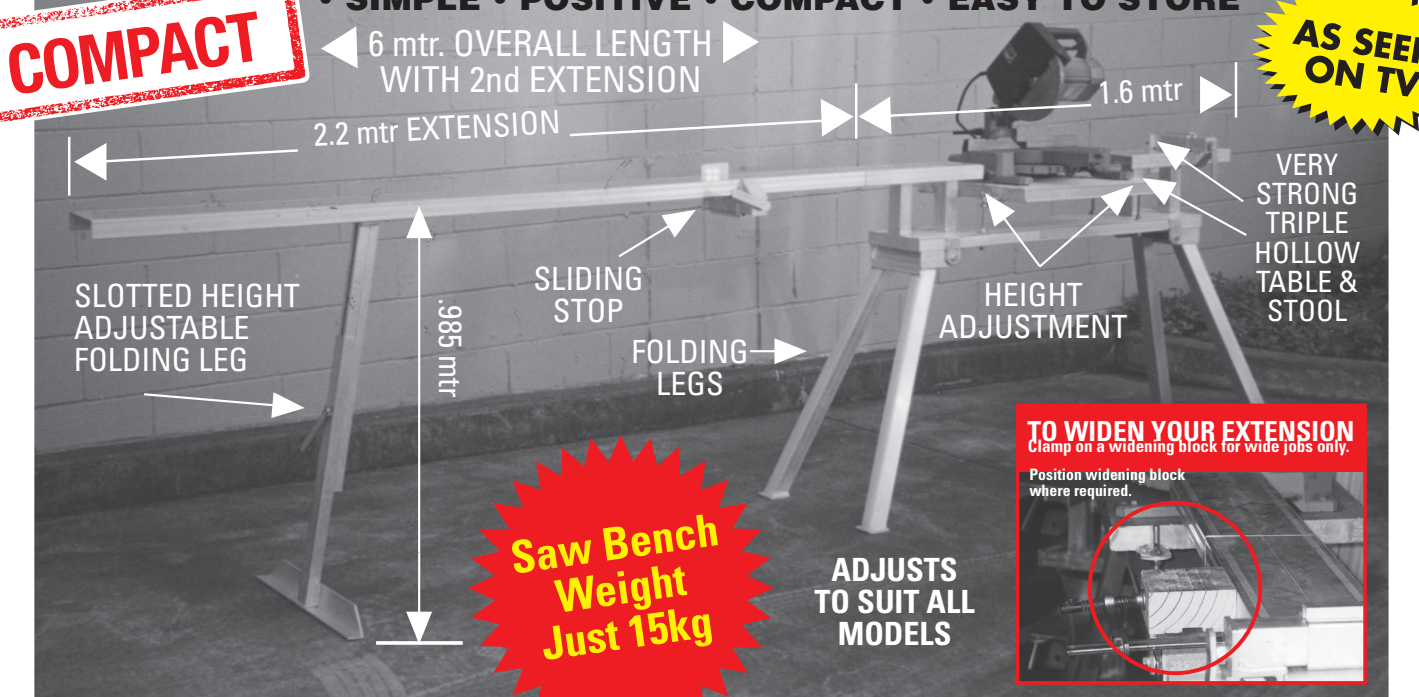

Saw Bench Weight Just 15kg

ADJUSTS TO SUIT ALL MODELS

TO WIDEN YOUR EXTENSION
Clamp on a widening block for wide jobs only.
Position widening block where required.

AS SEEN ON TV

Tradesperson's now have access to a professional Drop-Saw Work Bench that is simple and quick to set up, fully adjustable, extremely stable and accurate with every cut... another "Tommy Tucker" innovation.

The robust aluminium stop is adjustable up to 2.95 metres from the saw blade, when using the extension.

An extra fence can be obtained in any position on top of the bench, by clamping an additional "Stop" upside down under the bench top. The tongue will protrude the bench top by 30 millimetres.

A 2.2 metre simple self-locking extension is optional and can be fitted to either end of the bench. The extension has a folding leg and is slotted for precise height adjustment.

When two extensions are fitted (one to each end of the bench), the total overall length of the bench top is 6 metres.

A tradesperson working with several different models of saws can interchange with minimal adjustment by following these quick tips:

- purchase one additional platform for each saw type;
- use spacer blocks or bolt sleeves to obtain a uniform height between the bottom of the platform and the top of the saw table.

Interchanging of saws or with other tools can be performed in just seconds by removing four wing nuts.

- Bench Tested to 1 Tonne
- Fits all Drop Saws
- Adjustable Height

TOMMY TUCKER GUARANTEES YOUR MONEY BACK IF THE TRADE QUALITY HEAVY DUTY ALUMINIUM DROP-SAW WORK BENCH IS UNSUITABLE FOR YOUR SAW MODEL.

BASIC PACKAGE

TOTAL PRICE - \$645.00
Price includes:

- 1 x SAW BENCH
- 1 x SAW PLATFORM
- 2 x STOP/FENCE (Dual purpose)
- 1 x 2.2 mtr EXTENSIONS

REPLACEMENT PARTS AVAILABLE:

- SAW BENCH \$314.00 each
- SAW PLATFORM \$67.50 each

COMPLETE PACKAGE

TOTAL PRICE - \$810.00
Price includes:

- 1 x SAW BENCH
- 1 x SAW PLATFORM
- 2 x STOP/FENCE (Dual purpose)
- 2 x 2.2 mtr EXTENSIONS
- STOP/FENCE \$47.50 each
- 2.2 mtr EXTENSION \$167.00 each
- 1.1mtr EXTENSION \$126.00 each

STEP STOOL

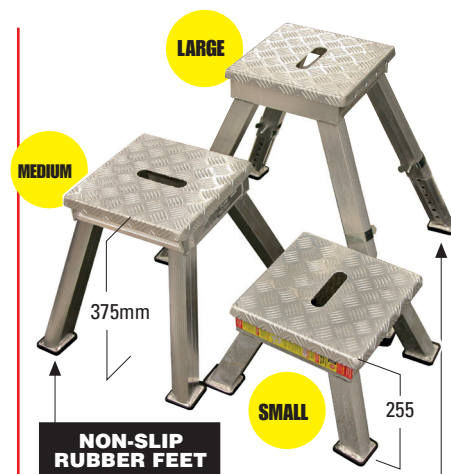

NON-SLIP RUBBER FEET

FAST FITTING PIN-CLIP

AVAILABLE IN TWO TOP SIZES

320mm sq. TOP	450mm sq. TOP
SMALL 255mm \$135	SMALL 255mm \$155
MEDIUM 375mm \$145	MEDIUM 375mm \$165
LARGE STOOL with ADJUSTABLE LEGS 430mm to 590mm \$190	LARGE STOOL with ADJUSTABLE LEGS 430mm to 590mm \$210

205kg Working Load Limit

DROP-SAW WORK BENCH - SET-UP INSTRUCTIONS

- Fold out both legs of the Saw Bench into the fully open position.
- Saw Bench must be positioned on a flat level surface.
- Fit Platform.
- Place the Drop-Saw on top of the aluminium Platform.
- Adjust the height of the Platform by turning the four Nylock nuts provided so as the saw table is level with the channel top.
- Align the fence of the saw with the outer edge of the 150mm wide saw bench channel top by using a straight edge.
- Drill at least 2 x 10mm holes through the base of the Drop-Saw and through the aluminium Platform.
- To bolt the Drop-Saw down, use at least 2 x 10mm hex bolts with Nylock nuts and tighten.
- To secure the Platform to the Bench use one wing nut on each of the four height adjusting rods.

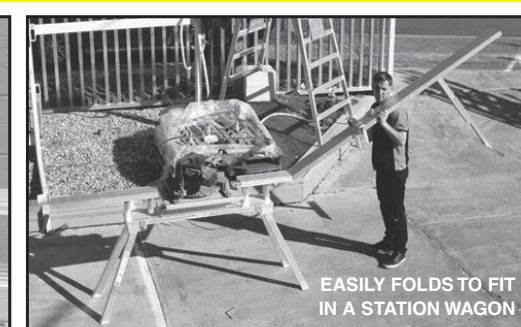
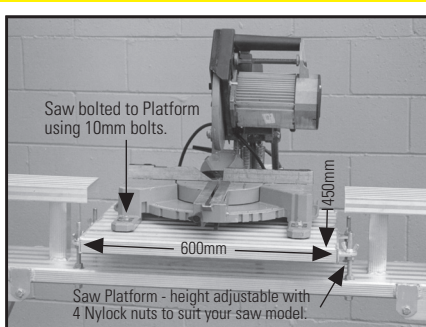

The work bench is suitable for left or right handed operators and will improve your work flow and productivity.

PRICES INCLUDE GST