

PROPER SELECTION

**FOR YOUR SAFETY
PLEASE READ CAREFULLY**

PROPER SELECTION

Select a trestle/ladder of suitable length to reach the working height required.

INSPECTION

1. Inspect trestle/ladder upon receipt and before each use, to ensure the trestle/ladder is in good condition.
2. Keep ladder clean and free of grease, oil, mud, cement, paint, etc.
3. Do not make temporary repairs of damaged or missing parts. If parts or repairs are required contact the manufacturer immediately.
4. Destroy trestle/ladder if broken or exposed to fire or chemical corrosion.

DANGER

**Metal Trestles/Ladders
conduct ELECTRICITY.**

**Do not let Trestle/Ladder
come in contact with
LIVE WIRES.**

PROPER SET UP

1. Trestle/ladder must be in the full open position before work can commence.

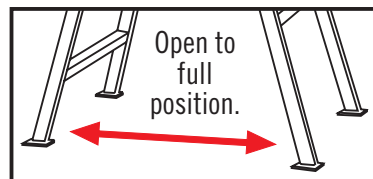

2. The trestle/ladder should be set up so as all four legs are firmly on the ground, the rungs are level and the trestle/ladder is stable before climbing.
3. Leg levellers, regardless of whether they are internal or external are designed to level the trestle ladder and cannot be used to gain extra height.
4. When adjusting the level of the trestle/ladder remove pin clips from the legs and select the height desired, push pin clips into position ensuring both arms of clip are secured onto leg.
5. Platform must be kept clear and free of objects or tools that could trip or injure a person on or below the working platform.
6. Working platforms used in conjunction with trestle/ladders must be at least 450mm wide (equal to the width of 2 standard planks).

7. A maximum span of 5.5 metres is accepted if two aluminium planks are clamped together with a "Tommy Tucker Plank Clamp".
8. Allow no less than 250mm overhang at each end when the plank is placed onto the rung of the trestle as 250mm is the minimum overhang allowable. As a guide on overhang, the plank sides can be marked with tape 250mm from the end.

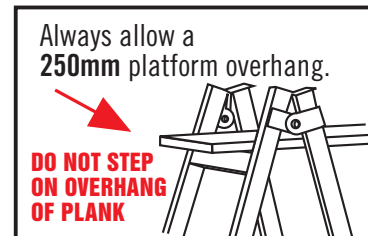

9. Please take notice of the work load limit on the trestle/ladder.

WARNING DO NOT OVERLOAD

10. Always test ground for hardness. If an 80kg man standing on the ball of his foot sinks, you will need timber plank off-cuts at least 300mm in length placed centrally under feet of the trestle.

**TOMMY TUCKER
TRESTLES**

AND PLANK FACTORY

8-10 Kenway Dr. Underwood, Q. 4119

(07) 3290 2705

Fax: (07) 3290 0155

Email: tommytuckertrestles@bigpond.com.au

Web: www.tommytuckertrestles.com.au

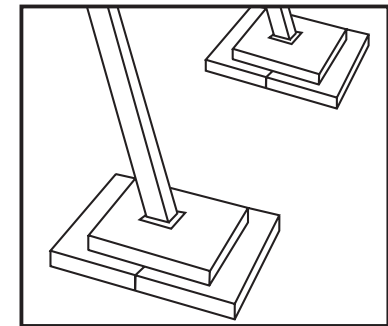

11. When extra stability is required, use Tommy Tucker Trestles (TRESTLE) counterweights.
12. For special upgrading of these trestles to work as a "Tommy Tucker Trestle Safety System" please talk to your supplier and obtain a copy of the "Tommy Tucker Trestle Safety System" guide sheet by "Tommy Tucker Trestles".
13. Do not use in rain, snow or icy conditions.
14. Do not use this trestle/ladder if your sense of balance is impaired in any way.
15. Access to the trestle/ladder platform will comply with requirements of state height regulations and applicable ladder standards.

The manufacturer
Tommy Tucker Trestles Pty. Ltd.

will not be responsible for damage or injury to persons through misuse of this product.